

Electric Vehicle Cooling System Application

THINKING SENSOR

Electric Vehicle Application

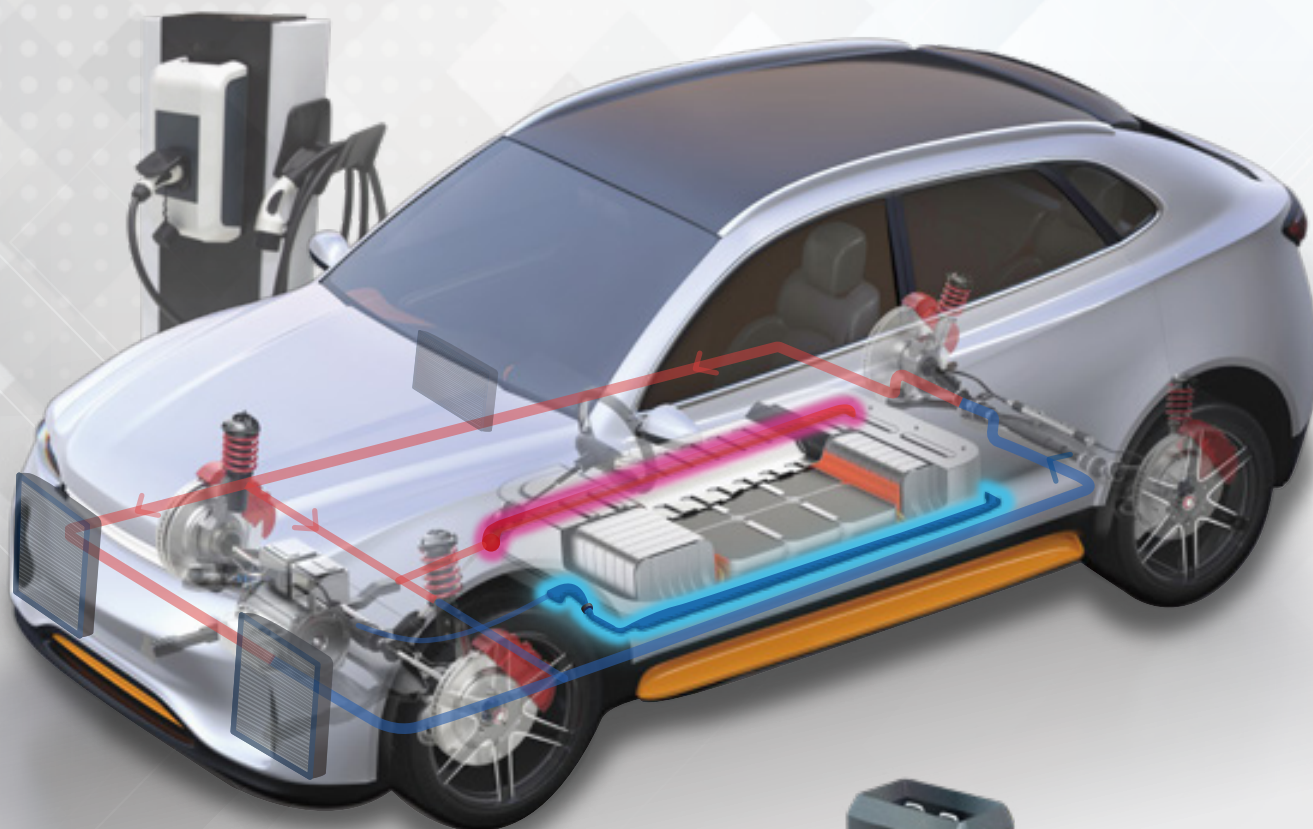

Electric Vehicle Cooling System Application

Inline Flow-Through Fluid Temperature Sensor

Applications

- EV battery pack coolant loop temperature monitoring

Features

- High measurement accuracy with the temperature shift controlled within 1°C
- Connector integration with the tube saves installation spaces
- Robust hydrolysis-resistant plastic tube
- Tube sizes, connectors, and electrical characteristics are customizable

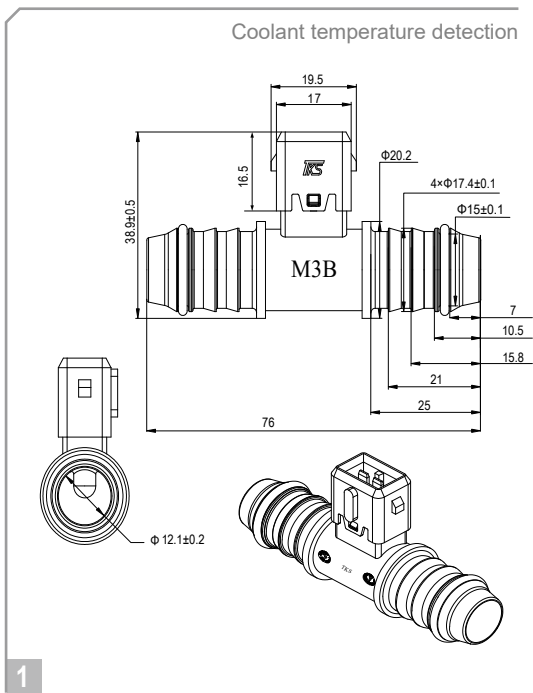

Feature | Hose barb fitting for mating with rigid polymer hose

Operation Temperature | -40~+125°C

Thermal Time Constant | Around 15 seconds (in water)

R Value & B Value Option 1 | R25:100KΩ±1%, B25/50: 3950K±1%

R Value & B Value Option 2 | R25:10KΩ±1%, B25/85: 3977K±1%

Insulation Test | DC 500V 100MΩ (Min)

Hi-Pot Test | AC 500V 0.5mA (Max)

Moisture Resistance | Pass 85°C 85% RH x 1000 hours test

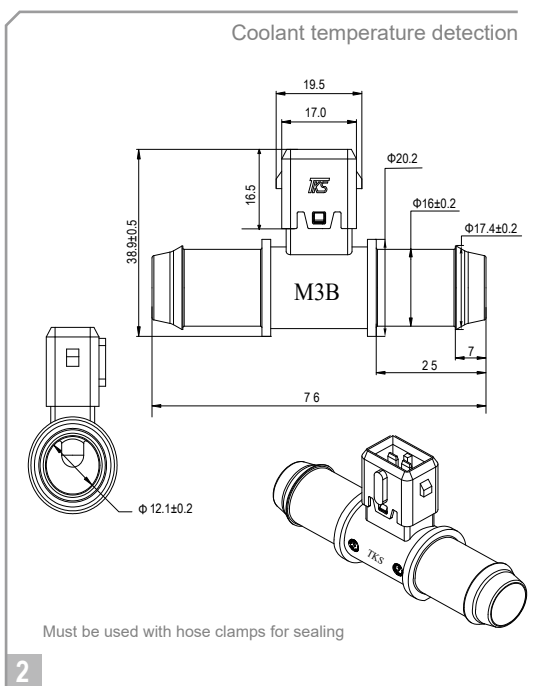

Feature | Designed for mating with elastomeric hose

Operation Temperature | -40~+125°C

Thermal Time Constant | Around 15 seconds (in water)

R Value & B Value Option 1 | R25:100KΩ±1%, B25/50: 3950K±1%

R Value & B Value Option 2 | R25:10KΩ±1%, B25/85: 3977K±1%

Insulation Test | DC 500V 100MΩ (Min)

Hi-Pot Test | AC 500V 0.5mA (Max)

Moisture Resistance | Pass 85°C 85% RH x 1000 hours test